



Product information



Technical documents
Download from PRO CLUB.

PACKAGED AIR CONDITIONERS NX SERIES 2022/2023

Panasonic



**Building Passion,
Building Solutions.**
Panasonic Air Conditioning Systems

We face a time in which "quality air" differentiates business. It's a time for Panasonic to fully display its strengths. Our ability to assemble and build superior systems isn't just due to the rich resources we have as a comprehensive electronics manufacturer, but also to Panasonic's 100 years of tradition, where each person thinks and acts on their own initiative while working in a team to reach further heights. We do not compromise. Each of our independent selves is a one stop solution. We face our customers' challenges together with our customers and do all that we can to build effective systems. As a true partner for our customers, we strive to always be at the forefront of business.

- Please read the Installation Instructions carefully before installing the unit, and the Operating Instructions before using it.
- Specifications are subject to change without prior notice.
- The contents of this catalogue are accurate as of August 30, 2022.
- Due to printing considerations, the actual colours may vary slightly from those shown.
- All graphics are provided merely for the purpose of illustrating a point.



Do not add or replace refrigerant other than the specified type. Manufacturer is not responsible for the damage and deterioration in safety due to usage of other refrigerant.

Authorised Dealer

PAC INVERTER ASIA October 2022



nanoeX



INVERTER



Panasonic A. P. Sales (Thailand) Co., Ltd.

18/6 Moo7, Bangna-Trad Road Km. 17,
Bangchalong, Bangplee, Samutprakarn 10540
Tel: 02-312-7148



QUALITY AIR FOR LIFE

NX Series Product Lineup

- All indoor units are equipped with nanoe™ X technology (Mark 2) as standard
- New DELUXE 4-Way Cassette, equipped with nanoe™ X technology (Mark 3)

Capacity [Btu/h]		18,100	24,000	30,000	36,200	42,000	48,100
4-Way Cassette	Indoor units nanoe™ X CONEX Generator Mark3	S-18PU3TA	S-24PU3TA	S-30PU3TA	S-3648PU3TA*		
	EGAT CLASS						
Adaptive Ducted	Indoor units nanoe™ X CONEX Generator Mark2	S-18PF3T	S-24PF3T	S-30PF3T	S-3648PF3T*		
	EGAT CLASS						
Ceiling Exposed	Indoor units nanoe™ X CONEX Generator Mark2	S-18PT3T	S-24PT3T	S-30PT3T	S-3648PT3T*		
	EGAT CLASS						
Outdoor Units	INVERTER R32	U-18PRH1T5	U-24PRH1T5	U-30PRH1T5	U-36PRH1T5	U-42PRH1T5	U-48PRH1T5
		—	—	—	U-36PRH1T8*	U-42PRH1T8*	U-48PRH1T8*

*3-phase model

NEW

Flexible Installation Adaptive Ducted

New NX Series Adaptive Ducted units can be mounted not only horizontally but also vertically without the need for alterations. Our groundbreaking drain pan design delivers a new level of flexibility in an industry-leading vertical installation.



Product information
Website will be opened in
November 2022

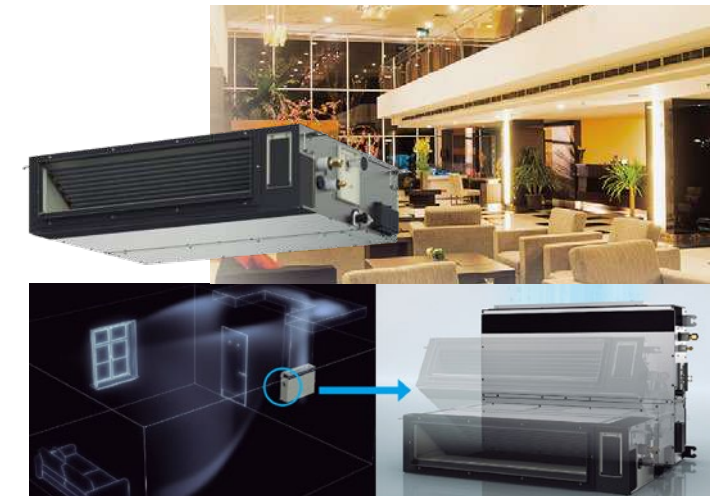

Compact Body with Powerful 150 Pa ESP

Indoor units have also been redesigned and are now just 250 mm in height and lighter in weight, yet still deliver the same powerful 150 Pa.

Space saving 250 mm height

NX Series

Height **250 mm** Weight* 25 kg
Note: In the case of 2HP



NEW

Higher nanoe™ X Concentration, Even in Large Spaces

nanoe™ X Generator Mark 3 providing a 100-fold increase in hydroxyl radical generation*. Greater effectiveness even in large spaces of more than 100 m².

* Compared to original nanoe™.

NEW

nanoe™ X Bringing Nature's Balance Indoors

The well-being benefits of nature are well known but do you know the power of hydroxyl radicals?

Abundant in nature, hydroxyl radicals (also known as OH radicals) inhibit pollutants, viruses and bacteria to clean and deodorise. nanoe™ X technology can bring these incredible benefits indoors.

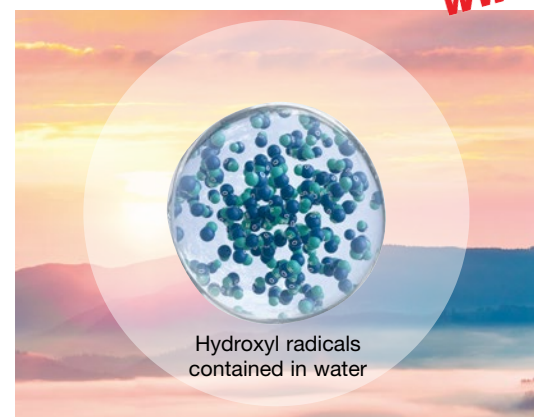

For 4-Way Cassette, nanoe™ X Generator Mark 3 Equipped.

7 Effects of nanoe™ X : Creating Cleaner Environments

nanoe™ inhibits 5 types of pollutants, deodorises and moisturises thanks to the action of hydroxyl radicals contained in water.

Deodorises



Odours

Inhibits 5 types of pollutants



Bacteria & Viruses



Mould



Allergens



Pollen



Hazardous substances

Moisturises



Skin & Hair



The evidence page of nanoe™ X effect

nanoe™ X Concentration Simulation: Generator Mark 3 for Highest Concentration Levels.

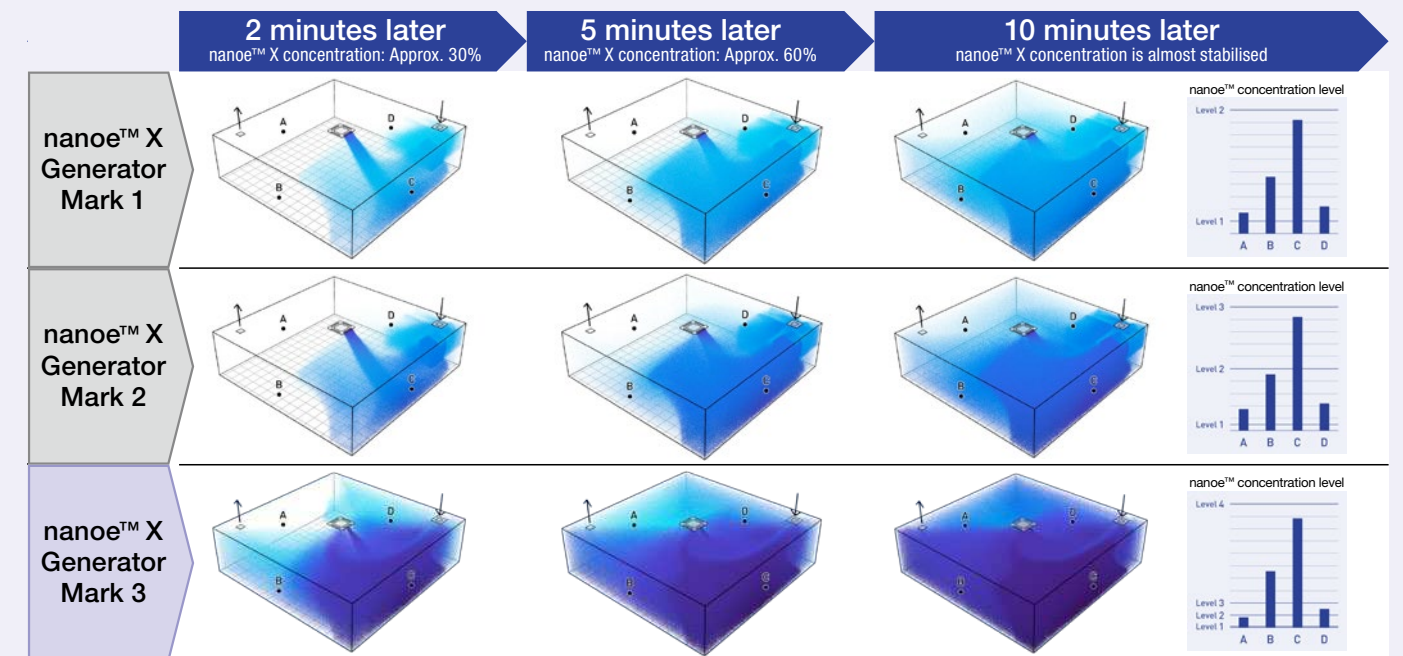

Conditions of the simulation : Verification space: 168 m³ / Room size: 70 m² / Room height: 2.4 m / Inspection model: 4-way cassette / Position of IDU: Centre

* There are 7 key benefits provided by nanoe which commence when concentration reaches level 1. The concentration level affects the speed at which the benefits occur. Concentration level 2 is 10 times the concentration of level 1, and concentration level 3 is 20 times the concentration of level 1. ** The results shown are for simulation purpose only and concentration may vary due to actual room conditions.

Advantages of New 4-Way Cassette

Compact, modern & flat panel design

Featuring uniform cooling, easy installation, and with a sleek exterior, this unit is the perfect match for all commercial applications.

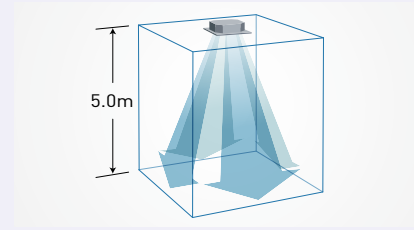

Powerful airflow

Thanks to its compact design the Twisted 3D Blade Fan increases airflow.

360° comfortable airflow

Air coming out of the centre of the discharge outlets travels farther. Air is discharged across a wide area from the four sides of the unit.

Wide flap

A wider main flap and sub flap reduce turbulence and increase airflow. Also, a wider angle jetting port allows airflow to reach as far as five metres.

* 4-Way Cassette : 3648PU type

Advantages of Outdoor Unit

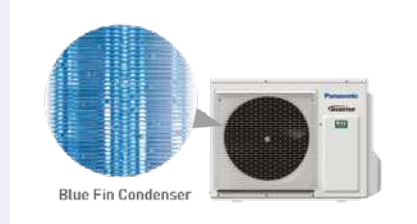

High durability outdoor unit

All Panasonic heat exchangers feature our Blue Fin technology, which offers enhanced corrosion resistance compared to non-Blue Fin models.



In-house manufactured compressor

Panasonic all in-house manufactured compressors are supplied to the world. The cumulative total of high-quality compressors in use has reached 580 million units*.

*As of September 2019. (In-house research)



Next generation R32 refrigerant

Compared to R22 and R410A, R32 has a very low potential impact on the depletion of the ozone layer and global warming.

Installation Instruction

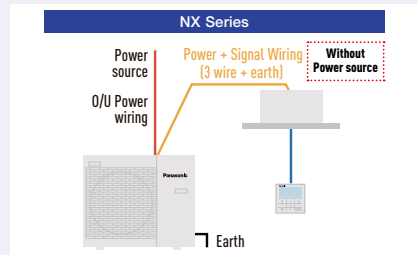

3 wire method

This NX series has been developed with 3 wire method and communication.

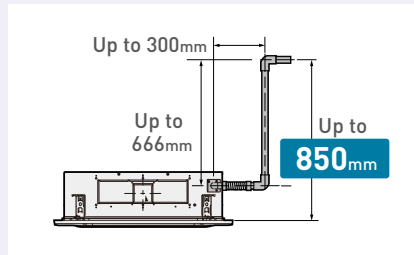

A strong and quiet drain pump

The drain pump can pump water up to a height of 850 mm, making drain pipe layout easy. Supports for 4-way Cassette.

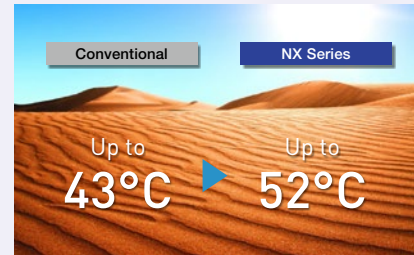

NEW Operation temperature

New NX series are capable of working even in the most difficult ambient conditions. Operating range expanded up to outdoor air temperature of 52°C.

4-WAY CASSETTE

- With the further advanced air purification technology of nano[™]X Generator Mark 3.
- Powerful industry-leading, 360° wide, comfortable airflow.
- The drain pump can pump water up to a height of 850 mm, making drain pipe layout easy.



Capacity [Btu/h(Phase)]	18,100	24,000	30,000	36,200	36,200 (3)	42,000	42,000 (3)	48,100	48,100(3)	
Power Source	220V, 10Phase - 50Hz		220V, 10Phase - 50Hz		380V, 30Phase - 50Hz		220V, 10Phase - 50Hz		380V, 30Phase - 50Hz	
Indoor Unit	S-18PU3TA	S-24PU3TA	S-30PU3TA	S-3648PU3TA	S-3648PU3TA	S-3648PU3TA	S-3648PU3TA	S-3648PU3TA	S-3648PU3TA	
Outdoor Unit	U-18PRH1T5	U-24PRH1T5	U-30PRH1T5	U-36PRH1T5	U-36PRH1T5	U-42PRH1T5	U-42PRH1T5	U-48PRH1T5	U-48PRH1T5	
Panel	CZ-KPU3H	CZ-KPU3H	CZ-KPU3H	CZ-KPU3H	CZ-KPU3H	CZ-KPU3H	CZ-KPU3H	CZ-KPU3H	CZ-KPU3H	
Cooling Capacity: Rated (Min-Max)	kW Btu/h	5.30 (2.00-6.00) 18,100 (6,820-20,500)	7.00 (2.10-8.00) 24,000 (7,170-27,300)	8.80 (2.10-10.00) 30,000 (7,170-34,100)	10.60 (3.80-11.20) 36,200 (13,000-38,200)	10.60 (3.80-11.20) 36,200 (13,000-38,200)	12.30 (3.80-14.00) 42,000 (13,000-47,800)	12.30 (3.80-14.00) 42,000 (13,000-47,800)	14.10 (5.30-15.50) 48,100 (18,100-52,900)	14.10 (5.30-15.50) 48,100 (18,100-52,900)
Current: Rated (Max)	A	5.2 (9.1)	7.8 (12.0)	10.8 (15.5)	13.4 (25.5)	13.4 (25.5)	15.5 (26.0)	15.5 (26.0)	22.7 (28.0)	22.7 (28.0)
Power Input: Rated (Min-Max)	kW	1.08 (0.26-1.35)	1.69 (0.28-2.25)	2.32 (0.29-2.70)	2.71 (0.62-3.00)	2.71 (0.62-3.00)	3.55 (0.63-4.10)	3.55 (0.63-4.10)	4.60 (0.96-5.10)	4.60 (0.96-5.10)
COP/EER	W/W Btu/hW	4.91 16.76	4.14 14.20	3.79 12.93	3.91 13.36	3.91 13.36	3.46 11.83	3.46 11.83	3.07 10.46	3.07 10.46
SEER	Btu/hW	26.27	23.03	22.52	21.80	22.43	20.60	21.00	19.30	19.30
Indoor Unit										
Air Volume	m ³ /min cfm	25.0 882	25.0 882	34.5 1,220	34.5 1,220	34.5 1,220	36.4 1,285	36.4 1,285	36.4 1,285	36.4 1,285
Sound Pressure Level (Hi/L0)	dB (A)	42 / 35	42 / 35	46 / 41	46 / 41	46 / 41	47 / 41	47 / 41	47 / 41	47 / 41
Sound Power Level (Hi/L0)	dB (A)	57 / 50	57 / 50	61 / 56	61 / 56	61 / 56	62 / 56	62 / 56	62 / 56	62 / 56
Dimension	Indoor (HxWxD) Panel (HxWxD)	mm mm	256 x 840 x 840 44 x 950 x 950	256 x 840 x 840 44 x 950 x 950	319 x 840 x 840 44 x 950 x 950	319 x 840 x 840 44 x 950 x 950	319 x 840 x 840 44 x 950 x 950	319 x 840 x 840 44 x 950 x 950	319 x 840 x 840 44 x 950 x 950	319 x 840 x 840 44 x 950 x 950
Net Weight	Indoor Panel	kg	21 5	21 5	24 5	24 5	24 5	24 5	24 5	24 5
Outdoor Unit										
Sound Pressure Level	dB (A)	50	53	53	54	54	57	57	58	58
Sound Power Level	dB (A)	69	72	72	73	73	76	76	77	77
Dimension	Outdoor (HxWxD)	mm	695 x 875 x 320	695 x 875 x 320	695 x 875 x 320	996 x 980 x 370	996 x 980 x 370	996 x 980 x 370	996 x 980 x 370	996 x 980 x 370
Net Weight	kg	39	39	39	67	67	67	75	73	73
Piping Connection	Gas Pipe Liquid Pipe	mm (inch)	12.70 (1/2) 6.35 (1/4)	15.88 (5/8) 9.52 (3/8)	15.88 (5/8) 9.52 (3/8)	15.88 (5/8) 9.52 (3/8)	15.88 (5/8) 9.52 (3/8)	15.88 (5/8) 9.52 (3/8)	15.88 (5/8) 9.52 (3/8)	15.88 (5/8) 9.52 (3/8)
Pipe Length	Min-Max	m	5-50	5-50	5-50	5-50	5-50	5-50	5-50	5-50
Elevation Difference	m	30	30	30	30	30	30	30	30	30
Maximum Chargeless Length	Max	m	30	30	30	30	30	30	30	30
Additional Gas	g/m	15	25	25	25	25	25	25	25	25
Operation Range, Outdoor	Min-Max	°C	16-52	16-52	16-52	16-52	16-52	16-52	16-52	16-52

ADAPTIVE DUCTED

- Air intake from rear as standard. Industry-leading horizontal and vertical design.
- Powerful 150 Pa ESP and space saving 250 mm height, filter included.
- Built-in drain pump and selectable air inlet position (bottom and rear).

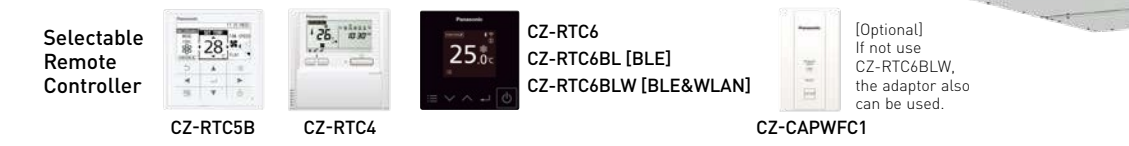

Capacity [Btu/h(Phase)]	18,100	24,000	30,000	36,200	36,200 (3)	42,000	42,000 (3)	48,100	48,100(3)	
Power Source	220V, 10Phase - 50Hz		220V, 10Phase - 50Hz		380V, 30Phase - 50Hz		220V, 10Phase - 50Hz		380V, 30Phase - 50Hz	
Indoor Unit	S-18PF3T	S-24PF3T	S-30PF3T	S-3648PF3T	S-3648PF3T	S-3648PF3T	S-3648PF3T	S-3648PF3T	S-3648PF3T	
Outdoor Unit	U-18PRH1T5	U-24PRH1T5	U-30PRH1T5	U-36PRH1T5	U-36PRH1T5	U-42PRH1T5	U-42PRH1T5	U-48PRH1T5	U-48PRH1T5	
Cooling Capacity: Rated (Min-Max)	kW Btu/h	5.30 (1.60-6.00) 18,100 (5,460-20,500)	7.00 (1.80-8.00) 24,000 (6,140-27,300)	8.80 (2.00-10.00) 30,000 (6,820-34,100)	10.60 (3.80-11.20) 36,200 (13,000-38,200)	10.60 (3.80-11.20) 36,200 (13,000-38,200)	12.30 (3.80-14.00) 42,000 (13,000-47,800)	12.30 (3.80-14.00) 42,000 (13,000-47,800)	14.10 (5.30-15.50) 48,100 (18,100-52,900)	14.10 (5.30-15.50) 48,100 (18,100-52,900)
Current: Rated (Max)	A	6.5 (9.1)	8.6 (12.0)	11.1 (15.5)	13.6 (25.5)	13.6 (25.5)	15.5 (26.0)	15.5 (26.0)	24.3 (28.0)	24.3 (28.0)
Power Input: Rated (Min-Max)	kW	1.35 (0.24-1.55)	1.85 (0.23-2.35)	2.39 (0.26-3.00)	2.76 (0.65-3.08)	2.76 (0.65-3.08)	3.70 (0.65-4.35)	3.70 (0.65-4.35)	4.91 (0.96-5.45)	4.91 (0.96-5.45)
COP/EER	W/W Btu/hW	13.41 46.13	12.97 44.29	12.55 42.86	13.12 45.32	13.12 45.32	11.35 38.84	11.35 38.84	9.80 33.52	9.80 33.52
SEER	Btu/hW	20.85	21.29	19.96	19.79	19.89	19.04	19.28	18.53	18.56
Indoor Unit										
Air Volume	m ³ /min cfm	14.0 495	21.0 740	36.0 1,270	36.0 1,270	36.0 1,270	36.0 1,270	36.0 1,270	36.0 1,270	36.0 1,270
External Static Pressure (Min-Max)	Pa	30 (10-150)	30 (10-150)	50 (10-150)	50 (10-150)	50 (10-150)	50 (10-150)	50 (10-150)	50 (10-150)	50 (10-150)
Sound Pressure Level (Hi/L0)	dB (A)	32 / 27	35 / 29	40 / 30	40 / 30	40 / 30	40 / 30	40 / 30	40 / 30	40 / 30
Sound Power Level (Hi/L0)	dB (A)	55 / 50	58 / 52	63 / 53	63 / 53	63 / 53	63 / 53	63 / 53	63 / 53	63 / 53
Dimension	Indoor (HxWxD)	mm	250 x 800 x 730	250 x 1,000 x 730	250 x 1,400 x 730	250 x 1,400 x 730	250 x 1,400 x 730	250 x 1,400 x 730	250 x 1,400 x 730	250 x 1,400 x 730
Net Weight	kg	25	30	39	39	39	39	39	39	39
Outdoor Unit										
Sound Pressure Level	dB (A)	50	53	53	54	54	57	57	58	58
Sound Power Level	dB (A)	69	72	72	73	73	76	76	77	77
Dimension	Outdoor (HxWxD)	mm	695 x 875 x 320	695 x 875 x 320	695 x 875 x 320	996 x 980 x 370	996 x 980 x 370	996 x 980 x 370	996 x 980 x 370	996 x 980 x 370
Net Weight	kg	39	39	39	67	67	67	75	73	73
Piping Connection	Gas Pipe Liquid Pipe	mm (inch)	12.70 (1/2) 6.35 (1/4)	15.88 (5/8) 9.52 (3/8)	15.88 (5/8) 9.52 (3/8)	15.88 (5/8) 9.52 (3/8)	15.88 (5/8) 9.52 (3/8)	15.88 (5/8) 9.52 (3/8)	15.88 (5/8) 9.52 (3/8)	15.88 (5/8) 9.52 (3/8)
Pipe Length	Min-Max	m	5-50	5-50	5-50	5-50	5-50	5-50	5-50	5-50
Elevation Difference	m	30	30	30	30	30	30	30	30	30
Maximum Chargeless Length	Max	m	30	30	30	30	30	30	30	30
Additional Gas	g/m	15	25	25	25	25	25	25	25	25
Operation Range, Outdoor	Min-Max	°C	16-52	16-52	16-52	16-52	16-52	16-52	16-52	16-52

CEILING EXPOSED

- Slim design with a thickness of only 235 mm.
- Compact looking, stylish, one-motion design.
- Comfortable, long-distance airflow distribution.



(Accessory) (Optional Wired Remote Controller)

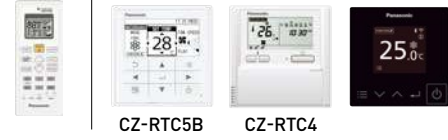

CZ-RTC6
CZ-RTC6BL [BLE]
CZ-RTC6BLW [BLE&WLAN]



CZ-CAPWFC1

[Optional]
If not use
CZ-RTC6BLW,
the adaptor also
can be used.



Capacity [Btu/h(Phase)]	18,100	24,000	30,000	36,200	36,200 [3]	42,000	42,000 [3]	48,100	48,100[3]	
Power Source	V/Phase Hz		220V, 1ØPhase - 50Hz		380V, 3ØPhase - 50Hz		220V, 1ØPhase - 50Hz		380V, 3ØPhase - 50Hz	
Indoor Unit	S-18PT3T	S-24PT3T	S-30PT3T	S-3648PT3T	S-3648PT3T	S-3648PT3T	S-3648PT3T	S-3648PT3T	S-3648PT3T	
Outdoor Unit	U-18PRH1T5	U-24PRH1T5	U-30PRH1T5	U-36PRH1T5	U-36PRH1T8	U-42PRH1T5	U-42PRH1T8	U-48PRH1T5	U-48PRH1T8	
Cooling Capacity: Rated (Min-Max)	kW		8.80 [2.00-10.00]		10.60 [3.80-11.20]		12.30 [3.80-14.00]		14.10 [5.30-15.50]	
Current: Rated (Max)	A		10.8 [12.0]		14.1 [25.5]		19.2 [26.0]		24.0 [28.0]	
Power Input: Rated (Min-Max)	kW		2.32 [0.26-2.79]		2.86 [0.68-3.04]		3.89 [0.68-4.45]		4.86 [0.94-5.37]	
COP/EER	W/W		4.12		3.71		3.16		2.90	
SEER	Btu/hW		23.82		23.41		21.77		19.99	
Indoor Unit										
Air Volume	m ³ /min	15.0	21.0	35.0	35.0	35.0	35.0	35.0	35.0	
Sound Pressure Level (Hi/L0)	dB [A]	38 / 29	40 / 32	46 / 38	46 / 38	46 / 38	46 / 38	46 / 38	46 / 38	
Dimension	Indoor (HxWxD)	mm	235 x 960 x 690	235 x 1,275 x 690	235 x 1,590 x 690	235 x 1,590 x 690	235 x 1,590 x 690	235 x 1,590 x 690	235 x 1,590 x 690	
Net Weight	kg	26	34	40	40	40	40	40	40	
Outdoor Unit										
Sound Pressure Level	dB [A]	50	53	53	54	57	57	58	58	
Dimension	Outdoor (HxWxD)	mm	695 x 875 x 320	695 x 875 x 320	695 x 875 x 320	996 x 980 x 370	996 x 980 x 370	996 x 980 x 370	996 x 980 x 370	
Piping Connection	Gas Pipe	mm (inch)	12.70 (1/2)	15.88 (5/8)	15.88 (5/8)	15.88 (5/8)	15.88 (5/8)	15.88 (5/8)	15.88 (5/8)	
Operation Range, Outdoor	Min-Max	°C	16-52	16-52	16-52	16-52	16-52	16-52	16-52	

4-WAY CASSETTE **NEW** Dimensions

- A S-18PU3TA/S-24PU3TA
- B S-30PU3TA/S-3648PU3TA

- 1 Air intake
- 2 Discharge outlet
- 3 Refrigerant tubing (liquid tube)
- 4 Refrigerant tubing (gas tube)
- 5 Drain tube connection port VP25 (outer dia. ø32)
- 6 Power supply port
- 7 Suspension bolt hole (4-12x30 elongated hole)

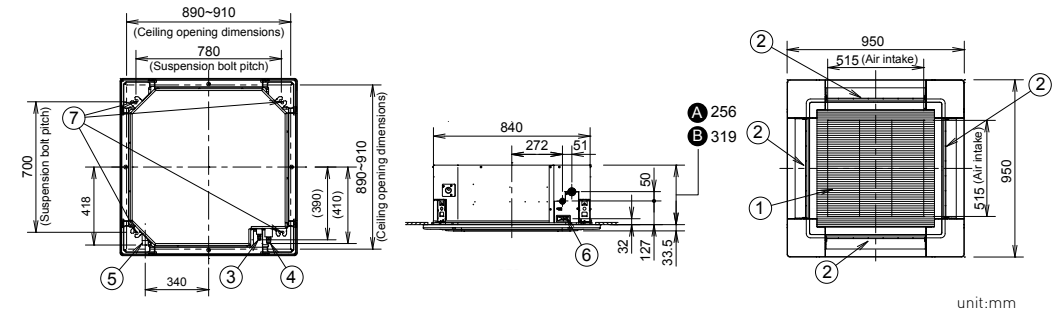

<Filter dimension> 520 x 520 x 15

ADAPTIVE DUCTED **NEW** Dimensions

S-18PF3T/S-24PF3T/S-30PF3T/S-3648PF3T

Detailed dimensions of indoor unit

Type	A	B	C	D	E	F
	mm	mm	mm	mm	mm	Qty
18	867	800	450 (Pitch 150 x 3)	71	592	12
24	1,067	1,000	750 (Pitch 150 x 5)	21	792	16
30/3648	1,467	1,400	1,050 (Pitch 150 x 7)	71	1,192	20

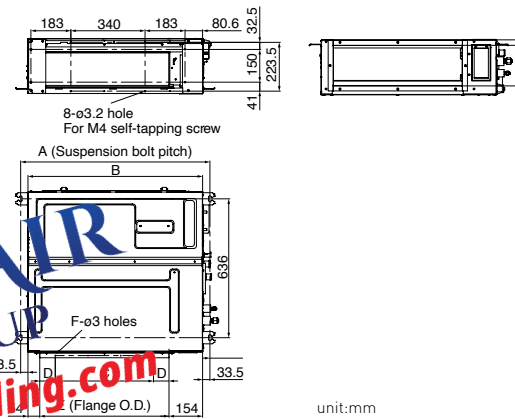

CEILING EXPOSED **NEW** Dimensions

S-18PT3T

S-24PT3T

S-30PT3T/S-3648PT3T

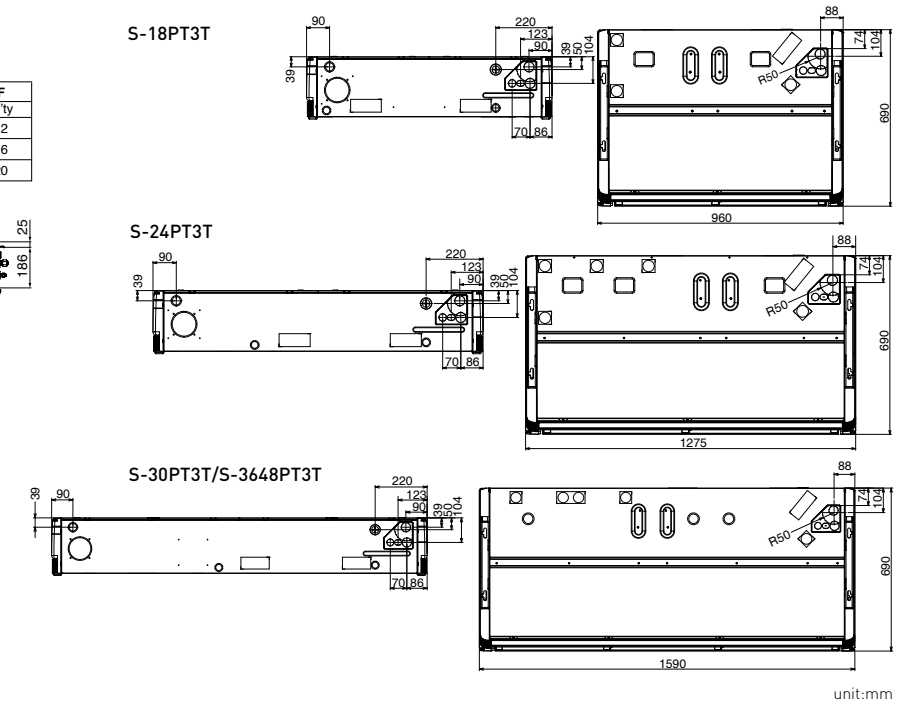

Advantages of Ceiling Exposed

Comfortable, Long-distance Airflow Distribution

The shape of the outlet has been optimised to provide long-distance air flow distribution.

Even in long rooms, air flow reaches every corner for exceptionally comfortable air conditioning.



*Results are based on specific testing conditions.

Remote Controller Information

Wireless Remote Controller

* For 4-Way Cassette & Ceiling Exposed



Wired Remote Controller

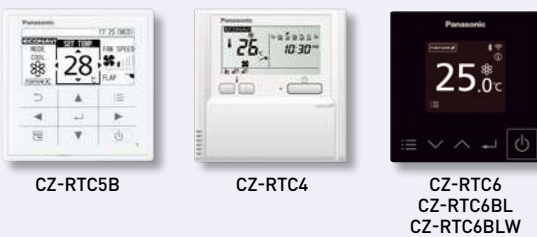

OUTDOOR UNITS **NEW** Dimensions

U-18PRH1T5/U-24PRH1T5/U-30PRH1T5

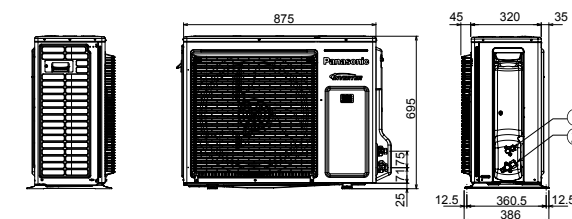

- 1 Refrigerant tubing (liquid tube), flared connection (Ø6.35"/1.62")
- 2 Refrigerant tubing (gas tube), flared connection (Ø12.70"/1.588")

*1 For U-18PRH
*2 For U-24/30PRH
*Mounting hole (4-R6.5), anchor bolt : M10

U-36PRH1T5/U-36PRH1T8/U-42PRH1T5/U-42PRH1T8/ U-48PRH1T5/U-48PRH1T8

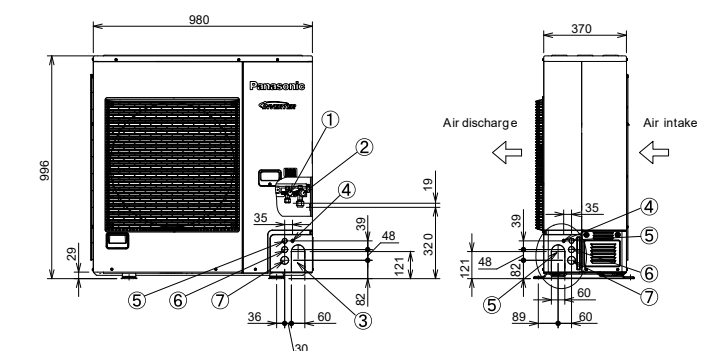

- 1 Refrigerant tubing (liquid tube), flared connection (Ø9.52)
- 2 Refrigerant tubing (gas tube), flared connection (Ø15.88)
- 3 Refrigerant tubing port
- 4 Electrical wiring port (Ø13)
- 5 Electrical wiring port (Ø22)
- 6 Electrical wiring port (Ø27)
- 7 Electrical wiring port (Ø35)

*Mounting hole (4-R6.5), anchor bolt : M10

unit:mm